



# MO SERIES X-MOP6 Inclined Module Combination Dust Collector



Strong Dust Removal



Efficient filtration



Dual filter  
cartridge design



Easy operation



Lower wind noise



Saving energy and  
environmental protection

It can save up to

# 40%

of the filter elements  
while requiring  
less space

Double filter cartridge design for better dust  
removal effect

The excellent performance of the new X-MOP6 slant insertion module combination dust collector is a result of Shanghai VIHCH's continuous dedication to research and improvement, aiming to exceed customer expectations. Under the same working conditions, it can save up to 40% of filter element numbers by selecting a smaller model compared to traditional filter element dust collectors. The more compact dust collector not only reduces the initial investment cost for businesses but also saves valuable factory space, as well as reducing the costs associated with changing filter elements. This ingeniously designed dust collector, combined with Shanghai VIHCH's nanofiber filtration technology, is truly a smart and intelligent design. It features an easy and quick replacement of filter elements due to its slant insertion method. The device is carefully crafted using laser cutting, numerical control machining, tool welding, modular manufacturing, electrostatic spray-painting, and LEGO-style assembly.

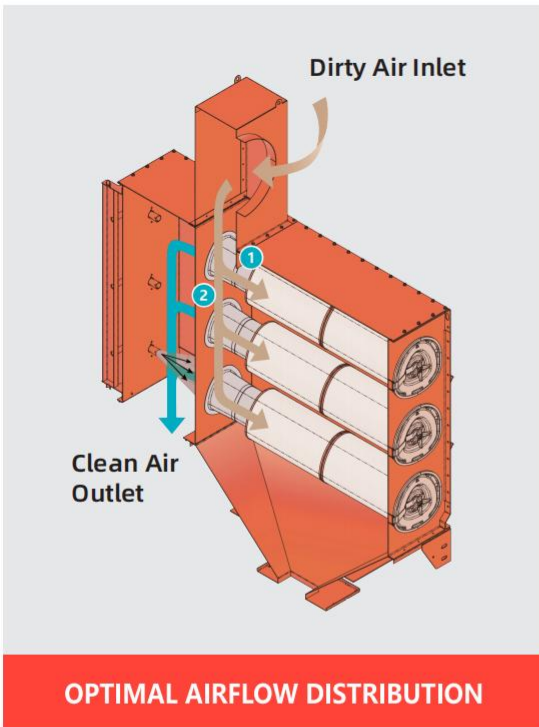

## Unique Inlet Design

### 1 Revolutionary Airflow Processing

Directly introduce the incoming airflow into a cleverly designed sedimentation area to reduce the filtering load on the filter element.

### 2 Breakthrough Dust Removal Design

The new pulse automatic dust removal system increases dust removal energy by 27%.



### 3 Forward-looking Filtering Design

Effectively arrange more filtration material at the beneficial location of the filter element, ensuring high standards of filtration efficiency while maintaining simple installation and risk-free leakage prevention.

## Versatility Flexibility in Design



### Slant Insertion Filter Core Assembly

The filter core adopts a slant insertion installation method, avoiding contact with dust during filter core replacement to prevent harm. This makes it easier and safer to remove and replace the filter cartridge.



### High Efficiency Flame Retardant Polyester Filter Core

You can select different filtration materials according to the type of pollutants for more effective trapping and efficiency.



### Manual Slide Valve

Assemble the hopper and bracket together, simply place the housing on top of the hopper, and secure it with screws.



### Integrated Control System

Integrated PLC electrical controls all functions of the dust collector



### Bulging Side Panel

The bulging side panel creates more space between the filter cores, reducing the airflow velocity inside the housing and minimizing wear on the filter material

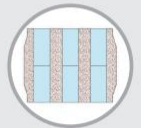

### Piping Connection Point

Select piping configurations based on site requirements to make the entire purification process more perfect



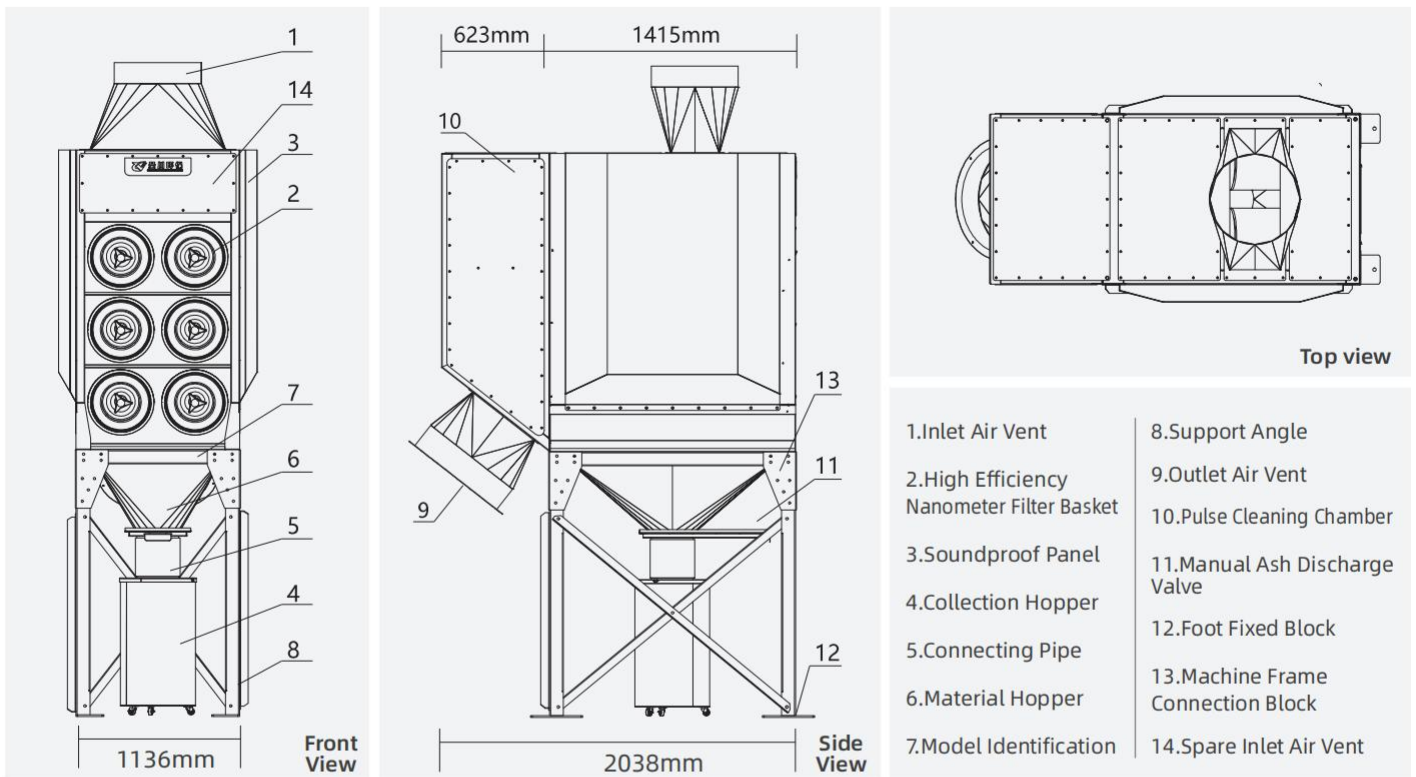

### Optional Combination

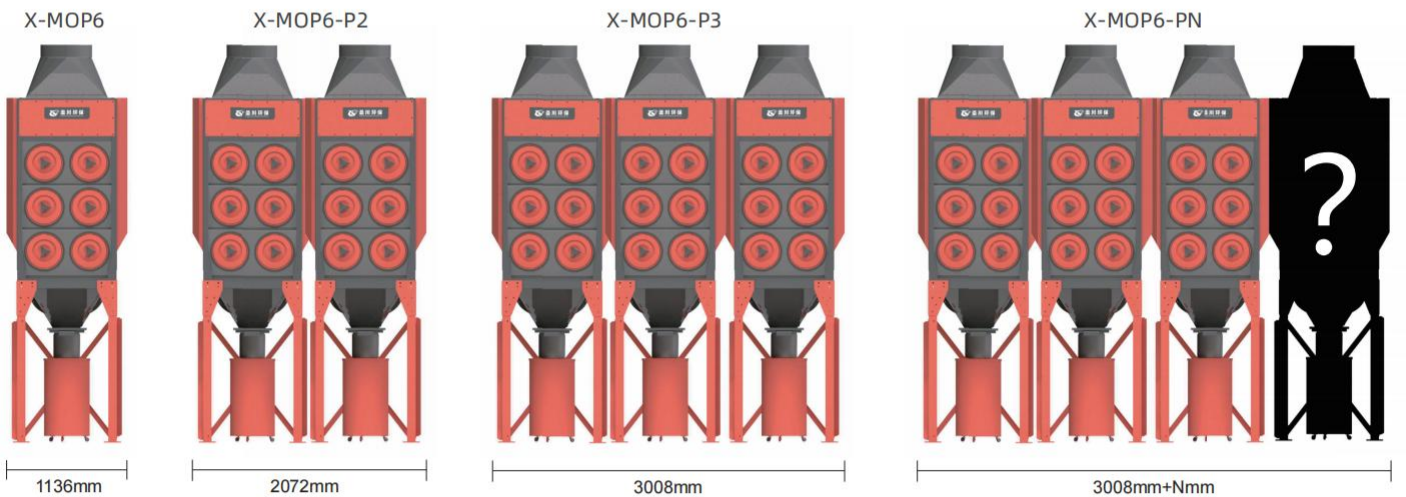

### Selection Parameter Table

Model Selection	Processing air volume	Control system	Pulse dust removal	Filter cartridge specifications	Number of filter cartridges	Filtering area	Dust collection efficiency	Fan brand	External Dimensions
X-MOP6	12000m <sup>3</sup> /h	PLC Touchscreen	Automatic	324*660mm	12	241.2m <sup>2</sup>	99.5%	Gaudat	2038*1136*3250mm
X-MOP6-P2	24000m <sup>3</sup> /h	PLC Touchscreen	Automatic	324*660mm	24	482.4m <sup>2</sup>	99.5%	Gaudat	2038*2072*3250mm
X-MOP6-P3	36000m <sup>3</sup> /h	PLC Touchscreen	Automatic	324*660mm	36	723.6m <sup>2</sup>	99.5%	Gaudat	2038*3008*3250mm
X-MOP6-PN	Nx12000m <sup>3</sup> /h	PLC Touchscreen	Automatic	324*660mm	Nx12	12Nx20.1m <sup>2</sup>	99.5%	Gaudat	2038*1136N*3250mm



## Application Areas

X-MOP6 Inclined Module Combination Dust Collector can be widely used to purify smoke and dust generated in various industries, steel, electric power, building materials, new energy, lithium battery, photovoltaic, chemical industry, food, electronics and other industries. The product has high purification efficiency and low noise. It has the characteristics of low life, long service life and small floor space.

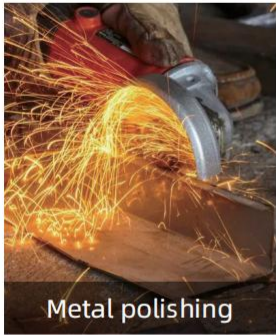

Metal polishing



Plasma cutting



Pharmacy

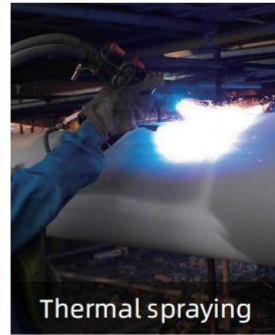

Thermal spraying

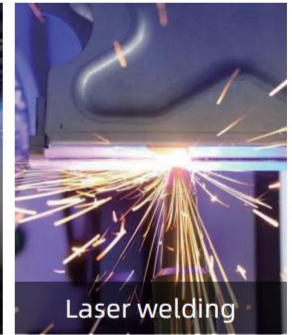

Laser welding

## Live Cases

Shanghai VHICH Environmental Protection Technology Co., Ltd. is equipped with high-quality engineering and technical service engineers, specializing in after-sales service. Convenient and timely to provide users with quality and satisfactory service is the commitment of Shanghai VHICH Environmental Protection Company.



## Optional Accessories



Spiral ventilation duct



Frequency converter



Temperature Sensor



Flameless relief device



Pipe spark arrester



Fire damper



Explosion proof valve



Automatic fire extinguisher



Spark detector



Explosive leaks