

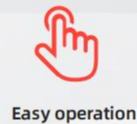

# SCT5-GZ SERIES<sub>17L10P1</sub>

## Dry Self-Cleaning Dust Collector

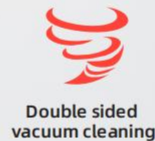
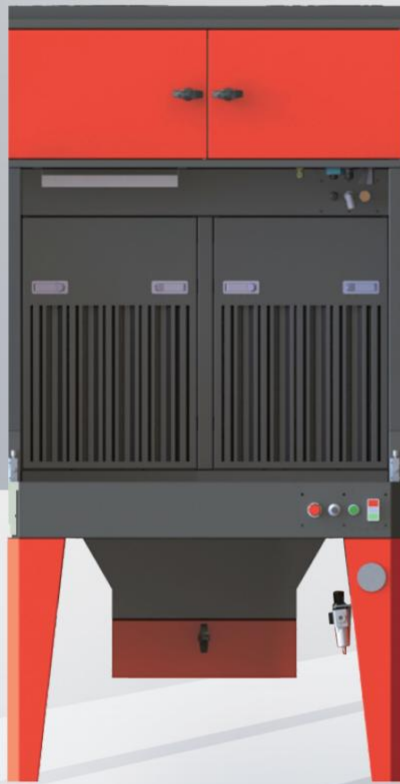

## Innovative Design

The SCT5-GZ series of dry self-cleaning dust collection tables is an air purification device primarily used for collecting and purifying various types of dust generated during processes such as cutting, grinding, polishing, stone material processing, biopharmaceutical manufacturing, etc. This workstation effectively captures fine suspended dust while not interfering with the daily operations of workers.

The dust collection table is mainly applied to small and medium-sized precision processing and irregular part processing operations. It can capture fine suspended dust without interfering with the daily work of the operators. Additionally, the dust collection table can be connected to specialized smoke and dust purifiers to achieve a higher level of dust removal efficiency, providing a clean and healthy working environment for the staff.

The side flaps of the dust collection table rotate open, and the top cover can be flipped up, allowing for the treatment of different shaped workpieces. For long workpieces like aircraft wing components, multiple dust collection table modules can be assembled in a modular fashion. The side flaps adopt an insertion design, enabling any combination of the dust collection tables to meet the sanding needs of workpieces of different lengths.

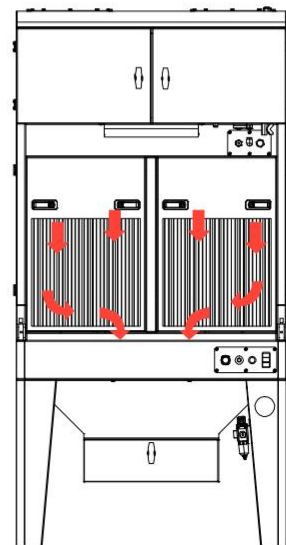



## Versatility Flexibility in Design

**Direct Insertion Filter Core**  
The filter core features direct insertion installation, avoiding contact with dust during filter core replacement to prevent harm, making it easier and safer to replace the filter core.

**Lateral bottom dual suction wind**  
Dual suction on both sides and below creates a larger wind volume and better dust removal effect.

**quick dust collection drawer**  
drawer-type dust collection drawer; Cleaning is very convenient and quick.

**The outlet muffler**  
Reduce fan noise to the lowest possible level through reasonable wind channel muffler design.

**Pulse Cleaning Chamber**  
Automatic cleaning of the equipment's filters is achieved through a gas pulse valve, effectively reducing maintenance costs and ensuring more stable equipment operation.

**Dynamic side door**  
The wing flaps rotate open, and the upper cover can also be flipped up, meeting the needs for grinding different shaped workpieces.

## Strong Filtration Capability



Smoke and dust enter the purifier through the negative pressure created by the fan and the exhaust port, entering the guide channel. Large particle dust collides with the deflector plate and falls into the ash drawer under gravity. Air containing fine particles enters the filtering chamber, passing through the outer surface of the filter core, trapping the dust on its surface. The accumulated dust on the filter core surface is periodically cleaned either manually or through pulse blowing, causing the dust particles deposited on the filter core surface to fall into the ash drawer under the impact of compressed air, resulting in a clean filter core surface. Purified air then exits through the fan.

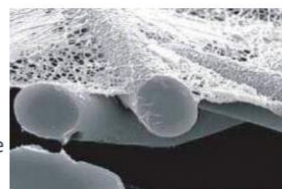

Enlarged image of clean filter material surface

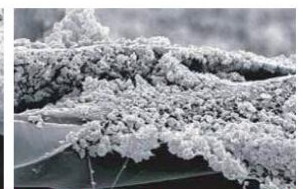

Enlarged image after filtering out extremely small particulates and smoke

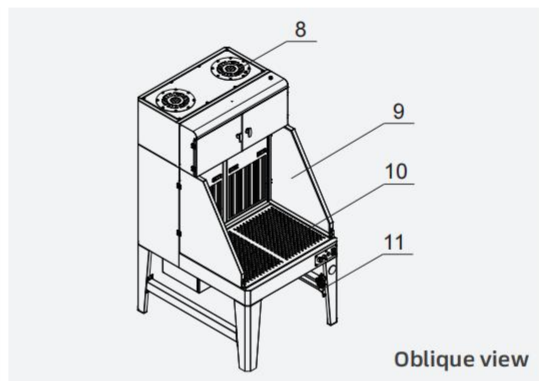
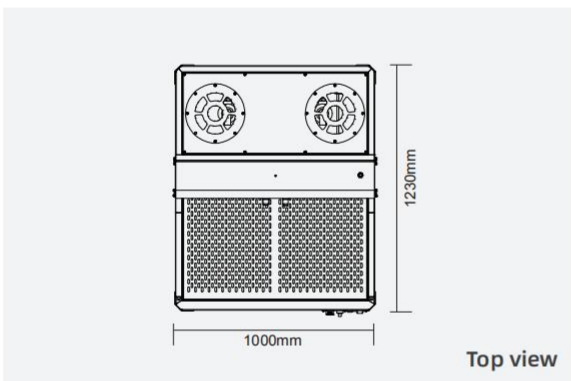
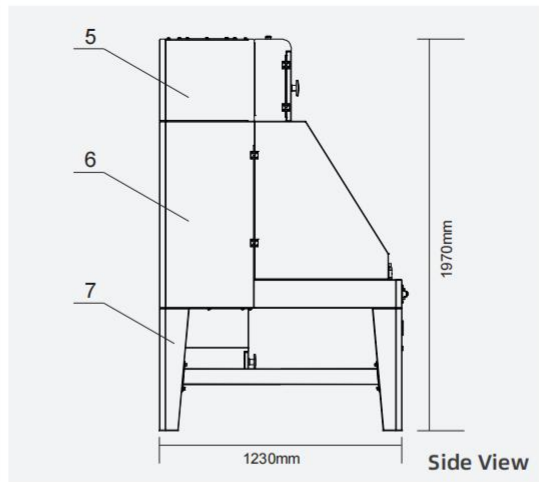
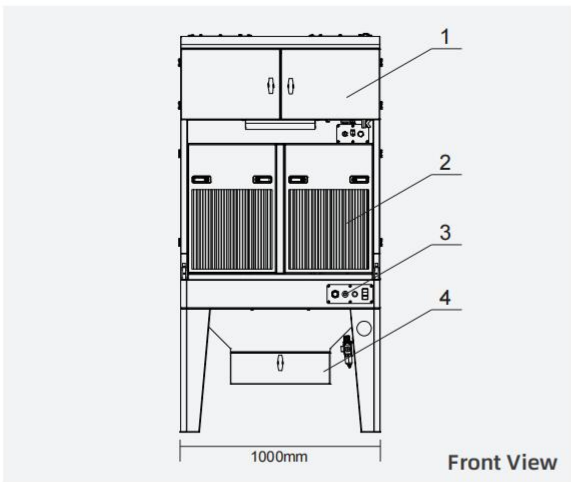

- 1. Electrical box
- 2. Side suction grille
- 3. Power switch
- 4. Ash box
- 5. Motor cavity
- 6. Filter core cavity
- 7. Legs
- 8. Top exhaust outlet
- 9. Side door panels
- 10. Sanding platform
- 11. Inlet

## Selection Parameter Table

Device Name	Dry Self-Cleaning Dust Collector	Pulse Dust Removal	Automatic
Device Type	Ground Jack/Cowl Panel Type	Filter Cartridge Configuration	Square flange/324*600mm (2 pieces)
Device Model	SCT5-GZ17L10P1	Filter Cartridge Material	Nano flame retardant/polyester
Device Power	1.7/KW	Filtering Area	40m <sup>2</sup>
Power Supply Voltage	380v/50Hz	Filtration Grade	GB12218-89-IV
Processing Air Volume m <sup>3</sup> /h	4500-6000	Dust Collection Efficiency	99.9%
Surface Suction Velocity	2.5-3.5M/S	Explosion Proof Function	Selective Configuration: Bursting Disc, Fire Extinguisher, Explosion Proof Electrical Equipment, Anti-static Filters
Fan Static Pressure Pa	1500-2000	Device Noise	50-70dB±3
Control System	Pulse Generator/PLC	Dust Collection Capacity	60L
Remote Control	Selected mating	Device Net Weight	250kg
Airflow Adjustment	Included	Dimensions (mm)	1000*1230*1970

## Product Diagram

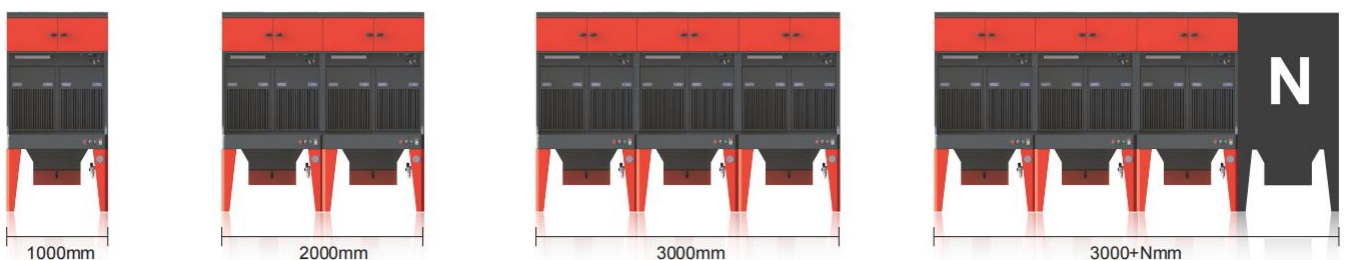



## Application Areas

The VHICH-SCT5 dry self-cleaning dust collection table can be widely utilized across various industries including steel, power, building materials, new energy, lithium batteries, photovoltaics, chemicals, food, electronics, etc., for the purification of smoke and dust, featuring high purification efficiency, low noise, long service life, and compact footprint.



Metal polishing



Plasma cutting



Pharmacy

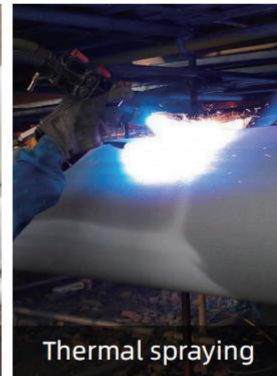

Thermal spraying

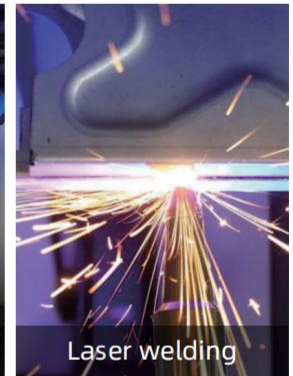

Laser welding

## Live Cases

Shanghai Sanchuan Environmental Protection Technology Co., Ltd. is equipped with high-quality engineering and technical service engineers, specializing in after-sales service. Convenient and timely to provide users with quality and satisfactory service is the commitment of Shanghai Sanchuan Environmental Protection Company.



## Optional Accessories



Air powered grinding machine



Grinding Machine



Miniature indexing table



Rotary base



Bench vise