



SCT6-550F4 SERIES

Hanging Cartridge Dust Collector



 Strong Dust Removal	 Efficient filtration	 Hanging design
 Easy operation	 Lower wind noise	 Saving energy and environmental protection

Innovative Design

The SCT6-series hosts all use top-mounted fans and occupy a small space. The entire purifier has low operating resistance and low noise. The SCT6-series host has a variety of models to choose from based on different air suction processing capabilities. The maximum air volume of a single set of standard products can reach more than 12,000m³/h. Through modular combination, larger air volume needs can be achieved. The SCT6-series filter cartridge is installed vertically on the box panel. Compared with the dust cleaning effect, the vertical effect is better. The function of the flower board is to separate the filter chamber and the air box. The upper part of the flower board is the pulse chamber of the air box, and the lower part is the filter chamber. When the dust-containing gas enters the internal air flow of the dust collector, larger particles fall into the ash hopper. The fine particles will enter the lower filter chamber with the air. The dust will adhere to the surface of the filter cartridge through high-voltage pulses. The purified air will enter the upper air box pulse The chamber is exhausted through the exhaust pipe.

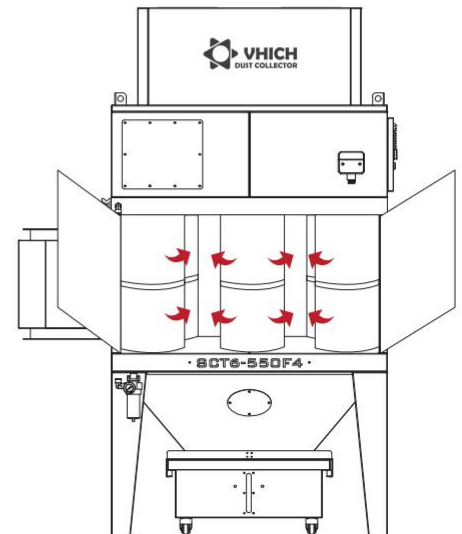



Versatility Flexibility in Design

Integrated control system
All function controls and feedback information are displayed on the display screen, and the main parameter settings are equipped with a password lock protection function to prevent misoperation.

Pulse cleaning chamber
The equipment filter is automatically cleaned through the gas pulse valve, which effectively reduces labor maintenance costs and makes the equipment more stable.

Quick dust box
The cylinder opening and closing dust box fixing method makes dust cleaning and dust box reset more convenient. A universal wheel with locking function is installed under the dust collection box for easy movement.

Silencer filter
The honeycomb increases the cross-sectional area of the airflow channel, reduces the wind speed and fully contacts the sound-absorbing cotton, greatly improving the sound-absorbing effect.

Vertical filter cartridge
It avoids dust accumulation and also improves the fire safety of the purifier.

Dust box protective cover
The protective cover of the dust box is multifunctional. It can prevent fire when the machine is running. It can also prevent dust during the cleaning and transportation of the dust box.



Nano/PTFE Coated Filter Technology

SCT6-series filters are designed with Nano/PTFE coated membrane filtration technology, which has a fine fiber layer diameter of 0.2 - 0.3 microns, capturing sub-micron pollutant-generated soot on the surface of the media, allowing dust to clump and coagulate, and making it easy to clean. Activation of the automatic cleaning function ensures less buildup on the surface of the cartridge, lower pressure drop, and clean air is discharged after filtration.

The filter cartridges selected for the SCT6-series have 25% more filtration area than similarly sized cartridges. Durable and easy to maintain.

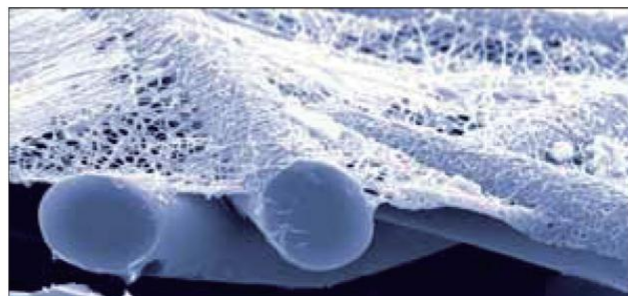

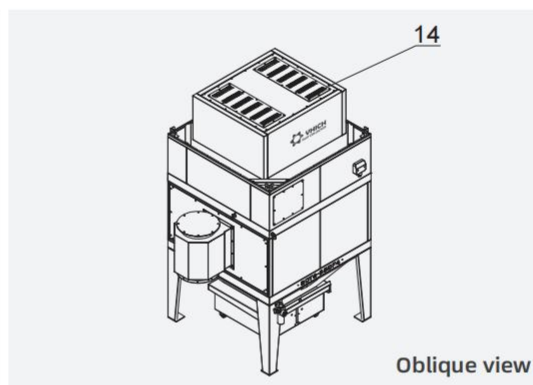
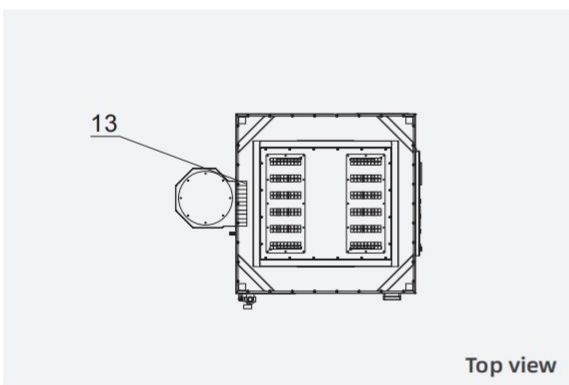
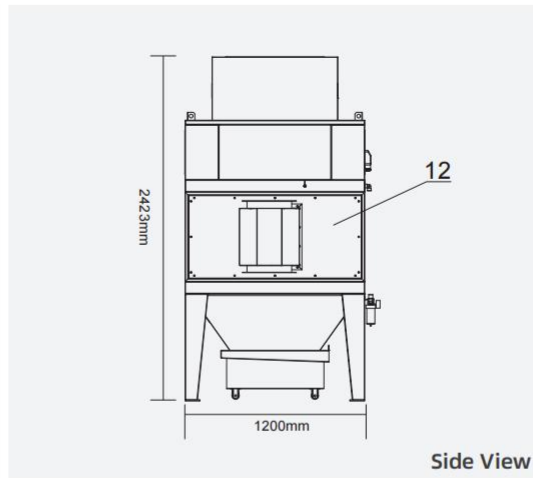
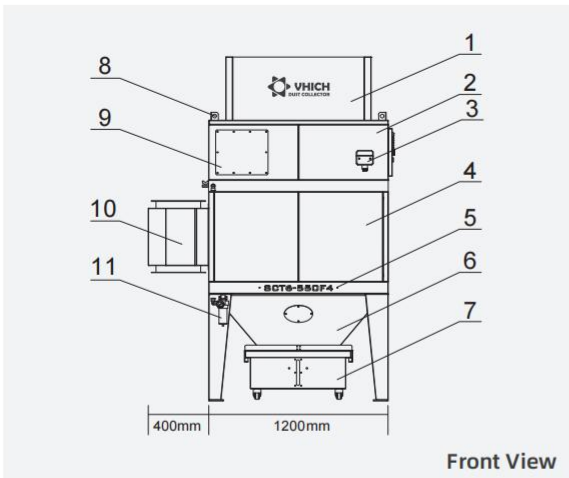

- 1. Fan cavity
- 2. Pulse cavity
- 3. Junction box
- 4. Filter cartridge cavity
- 5. Model plate
- 6. Ash collection bucket
- 7. Dust box
- 8. Lifting ears
- 9. Maintenance door
- 10. Air inlet device
- 11. Pressure regulating valve
- 12. Maintenance door
- 13. Spark arrester
- 14. Air outlet

Selection Parameter Table

Device name	Hanging cartridge dust collector	Pulse cleaning	automatic
Equipment type	Standard type	Filter cartridge configuration	4 barrels/324*660mm
Device model	SCT6-550F4	Filter cartridge material	Nano flame retardant
equipment power	5.5/KW	filter area	80-90m ²
voltage	380v/50Hz	filter level	GB12218-89-IV
Processing air volume	4000-4500m ³ /h	Dust removal efficiency	99.9%
Fan static pressure Pa	2800-3200	Explosion-proof function	Optional
Control System	Pulse controller	Equipment noise	70dB±5
Intelligent frequency conversion	ON/Optional configuration	Ash collection volume	60L
remote control	ON/Optional configuration	Equipment net weight	550kg
Air volume adjustment	ON/Optional configuration	Overall dimensions	1200*1200*2423mm
spark capture	Air inlet box + fire arrester net	Applicable machine tool size	3000*1500mm

Product pictures and external dimensions are for reference only and shall prevail in kind.



Application Areas

SCT6-series Hanging Cartridge Dust Collector can be widely used to purify smoke and dust generated in various industries, steel, electric power, building materials, new energy, lithium battery, photovoltaic, chemical industry, food, electronics and other industries. The product has high purification efficiency and low noise. It has the characteristics of low life, long service life and small floor space.

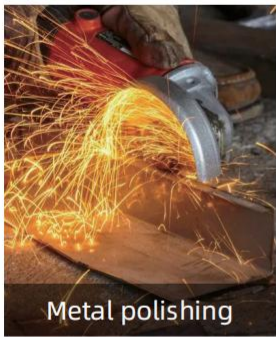

Metal polishing



Plasma cutting



Pharmacy

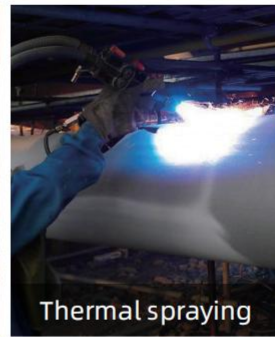

Thermal spraying

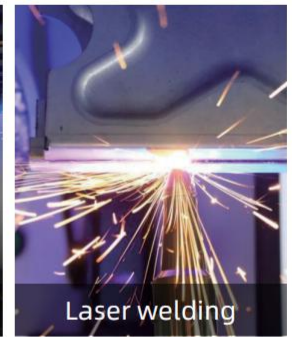

Laser welding

Live Cases

Shanghai VHIH Environmental Protection Technology Co., Ltd. is equipped with high-quality engineering and technical service engineers, specializing in after-sales service. Convenient and timely to provide users with quality and satisfactory service is the commitment of Shanghai VHIH Environmental Protection Company.



Optional Accessories



Spiral ventilation duct



Frequency converter



Temperature Sensor



Flameless relief device



Pipe spark arrester



Fire damper



Explosion proof valve



Automatic fire extinguisher



Spark detector



Explosive leaks