



SCT8-110F8X SERIES

Inclined type |
Cartridge dust collector | Leading model



Innovative Design

The SCT8 series is an independent integrated dust collector with multiple cartridge filters. A dust collector specially designed for dust generated by thermal cutting and welding processes. This equipment is widely used for dust removal in metal welding, laser cutting, plasma cutting and metal polishing industries.

- It adopts a downflow layout and a tilted filter cartridge installation structure, so the dust collector has a good synchronous cleaning effect during the working process;
- The purification efficiency is high, with a purification efficiency of more than 99.9% for dust above sub-micron. The equipment has low operating resistance, effectively saving the energy consumption of the dust removal system;
- The dust gas inlet is equipped with a dust shield, which has buffering and wear-resistant functions, preventing dust from directly impacting the filter cartridge at high speed, thus extending the service life of the filter cartridge;
- The 15° tilted drawer-type installation of the filter cartridge makes it easier to replace the filter cartridge, and there are no transmission parts in the dust collector body, which reduces maintenance work. For general dust, the filter cartridge can be used for a long time without replacement.
- Modular combination, the size can be selected at will, the original combination can be expanded, and dust removal units can be added without making too many changes to the original equipment.

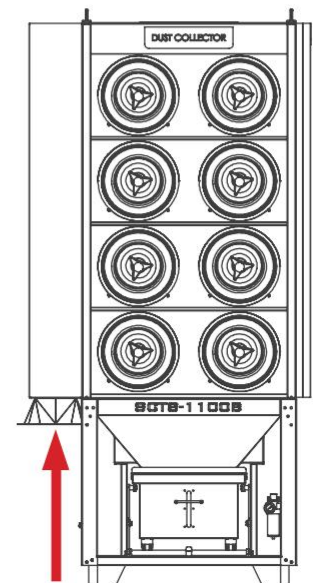

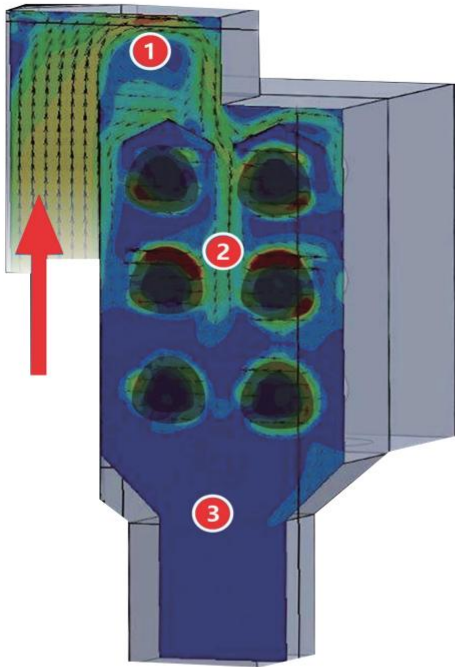

Optimum airflow distribution

1 Versatility Flexibility in Design

Simple piping provides ease of connection, and piping is installed from the start of fabrication, increasing processing and maximizing filtration capacity.

2 Airflow is evenly distributed

Minimizes high-velocity airflow for maximum efficiency and long-term filtration.

3 Low airflow disturbance area

Effectively reduce the airflow speed at the bottom of the hopper and maximize the dispersion of smoke and fine particles.

Versatility Flexibility in Design



Pulse cleaning chamber

Automatic cleaning of the equipment filter through the gas pulse valve, effectively reducing the cost of manual maintenance and making the equipment more stable



Disassembly and assembly of inclined filter element

The filter element is installed obliquely to avoid damage caused by contact with dust when replacing the filter element, making the removal of the filter cartridge more convenient and safer



High-efficiency flame retardant polyester filter element

Different filter materials can be selected according to the pollutants to realize more effective capture and efficiency



Air outlet silencer

Minimize fan noise through reasonable air duct silencer design



Integrated control system

Integrated PLC electrical appliances to control all dust collector operating functions



Quick dust box

The dust box is loaded and unloaded using the mechanical lever principle. The dust box is fixed by directional guide rails. It is equipped with universal casters for easy movement of the dust box, making cleaning the dust box very convenient and fast



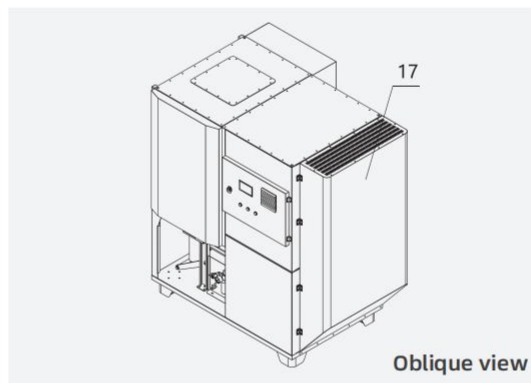
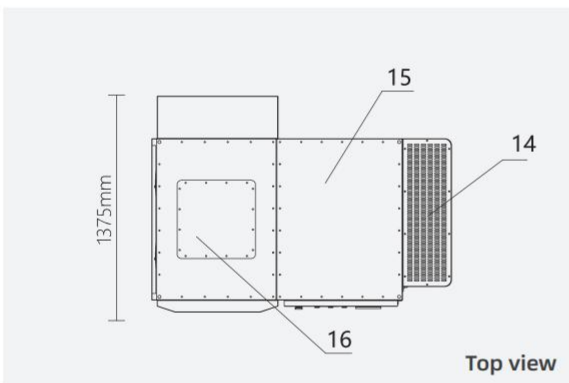
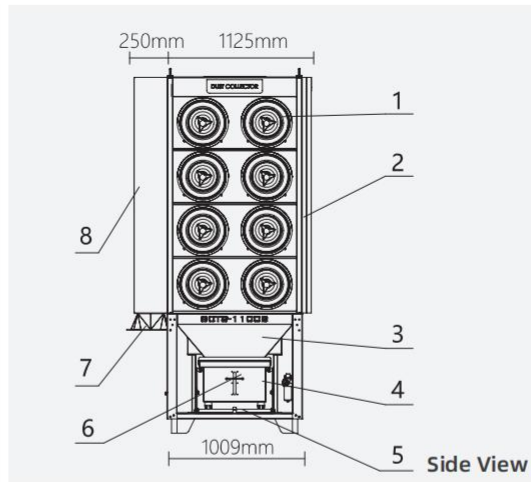
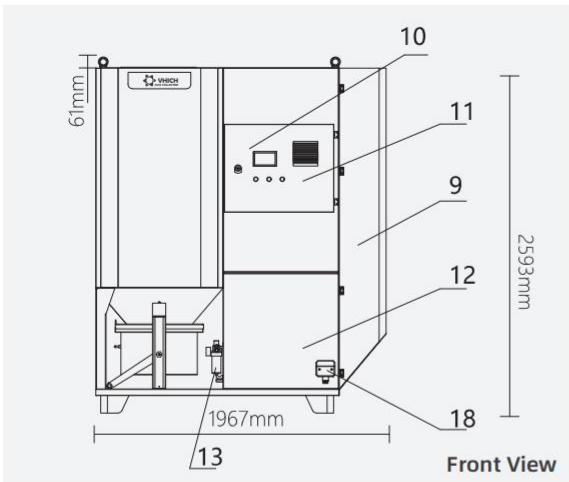

1. High-precision nano filter cartridge
2. Sound insulation board
3. Hopper/ash collection hopper
4. Dust box
5. Ash discharge lever
6. Observation window
7. Air inlet
8. Spark arrester
9. Air outlet duct
10. PLC control screen
11. Electrical system
12. Fan cavity
13. Oil-water separator
14. Air outlet
15. Pulse cleaning chamber
16. Upper air inlet
17. Silencer
18. Power junction box

Selection Parameter Table

Equipment name	Cartridge dust collector	Air pressure monitoring	Yes
Type	Energy-efficient	Intelligent frequency conversion	Yes
Model	SCT8-110F8X	Automatic fire extinguishing	Optional
Power	11.0/KW	Pulse cleaning	Automatic dust cleaning (intelligent dual mode)
Motor brand	Siemens	Filter cartridge material	Ahlstrom nano flame retardant filter paper/130g polyester fiber coating
Fan brand	VHICH	Explosion-proof function	Optional explosion vent discs, flameless explosion vents, explosion-proof electrical appliances, explosion-proof fans, motors, explosion-proof valves, and spark detection
Air volume	8000-11000		
Control System	PLC+Intelligent control screen	Filter cartridge configuration	8/324*1000
Electrical components	Schneider	Filter area	192m ²
Remote control	Yes (remote control transmission)	Noise	72dB±5
Spark capture	Spark arrester + flame arrester	Volume	65L
Differential pressure monitoring	Yes	Weight	1000KG
Temperature monitoring	Yes		
Air volume monitoring	Yes		

Product pictures and external dimensions are for reference only and shall prevail in kind.



Application Areas

Shengchuan SCT8 industrial cartridge dust collector can be widely used to purify smoke and dust generated in various industries, steel, electric power, building materials, new energy, lithium battery, photovoltaic, chemical industry, food, electronics and other industries. The product has high purification efficiency and low noise. It has the characteristics of low life, long service life and small floor space.

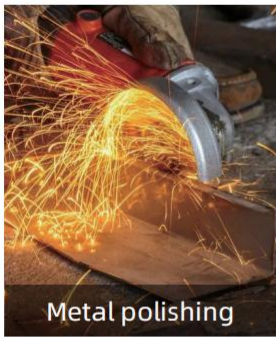

Metal polishing



Plasma cutting

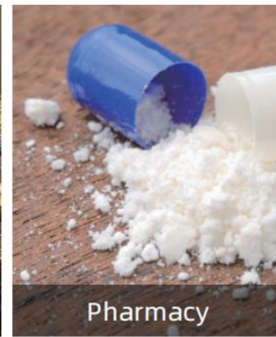

Pharmacy



Thermal spraying

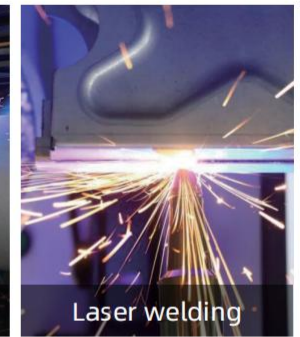

Laser welding

Live Cases

Shanghai Sanchuan Environmental Protection Technology Co., Ltd. is equipped with high-quality engineering and technical service engineers, specializing in after-sales service. Convenient and timely to provide users with quality and satisfactory service is the commitment of Shanghai Sanchuan Environmental Protection Company.



Optional Accessories



Spiral ventilation duct



Frequency converter



Temperature Sensor



Flameless relief device



Pipe spark arrester



Fire damper



Explosion proof valve



Automatic fire extinguisher



Spark detector



Explosive leaks