

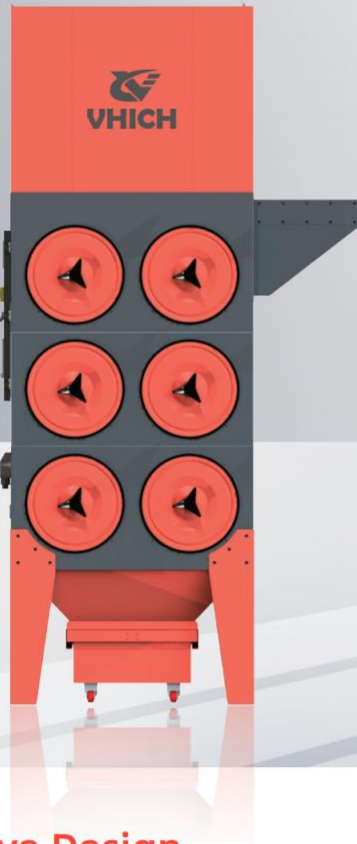

SCT8-750D6 SERIES

Horizontal plug-in type
Cartridge dust collector



 Powerful Suction	 Efficient filtration	 Downflow design
 Easy operation	 Lower wind noise	 Saving energy and environmental protection

Innovative Design

The SCT8-D series is a horizontally inserted independent integrated dust collector with multiple cartridge filters, designed for small flow dust collection application systems. It has the advantages of simple operation and control, small pressure difference, and low power of the fan motor. The horizontal plug-in cartridge dust collector adopts a downflow layout, so the dust collector has a good synchronous cleaning effect during the working process. The original combination can be expanded and dust removal units can be added without much modification to the original equipment. The uppermost row of filter cartridges will pulse backflush first, and then the controller selects the lower row to repeat the pulse backflush process. After that, the controller will continue to select other filter cartridges for pulse backflush operation. The horizontally installed filter cartridge occupies a relatively large area and is suitable for relatively large working environments. This equipment is widely used for dust removal in metal welding, laser cutting, plasma cutting and metal polishing industries.

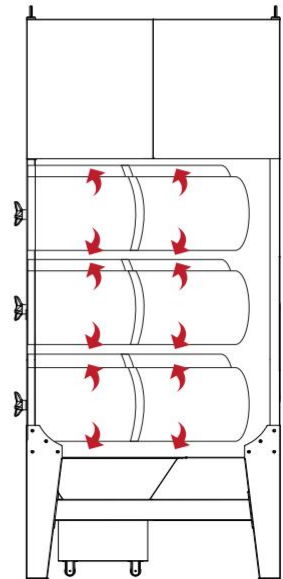

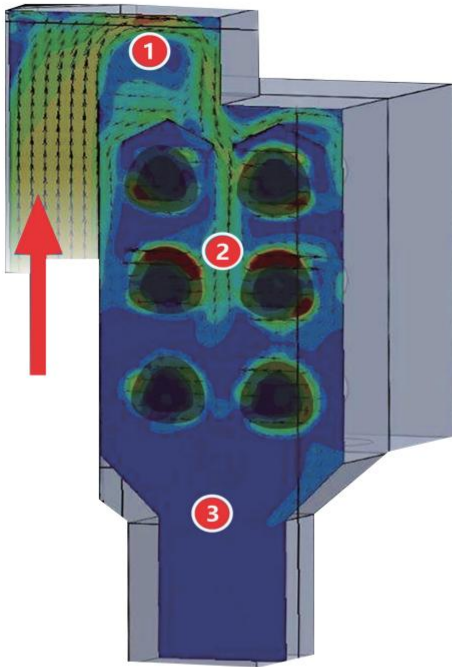

Optimum airflow distribution

1 Versatility Flexibility in Design

Simple piping provides ease of connection, and piping is installed from the start of fabrication, increasing processing and maximizing filtration capacity.

2 Airflow is evenly distributed

Minimizes high-velocity airflow for maximum efficiency and long-term filtration.

3 Low airflow disturbance area

Effectively reduce the airflow speed at the bottom of the hopper and maximize the dispersion of smoke and fine particles.

Versatility Flexibility in Design



Fan Silencer cavity

The upper structure of the fan adopts honeycomb fire-proof silencing cotton to reduce the operating noise of the fan to a reasonable range.



Interactive interface

Independently developed PLC fully intelligent control unit to make equipment operation simpler and smarter.



Water separator

Effectively filter contaminated external air sources through the oil-water separator, effectively protect the equipment filter element and extend the service life.



Air inlet fire blocking plate

The entrance is equipped with a stainless steel fire arresting device, which can effectively capture high-temperature dust and sparks and improve equipment safety.



Disassembly and assembly of horizontal plug-in filter element

The filter element is installed horizontally to avoid damage caused by contact with dust when replacing the filter element, making the removal of the filter cartridge more convenient and safer.



Convenient gray box collection

Large-capacity dust box design and quick buckle disassembly method make dust cleaning more convenient and efficient.



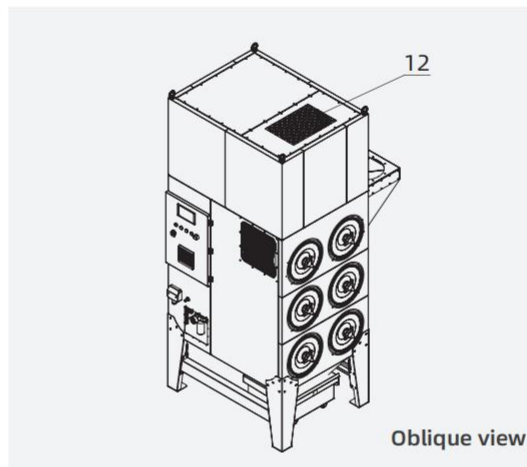
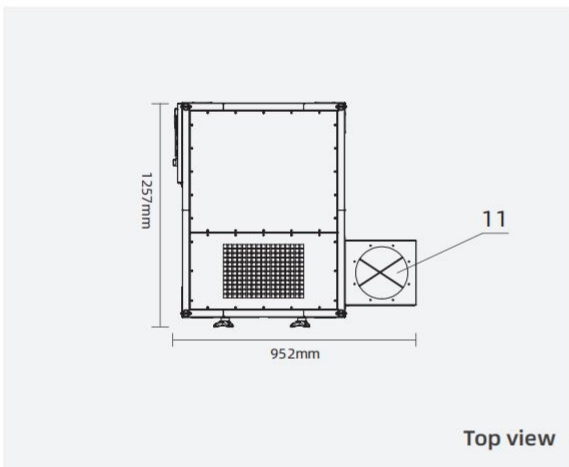
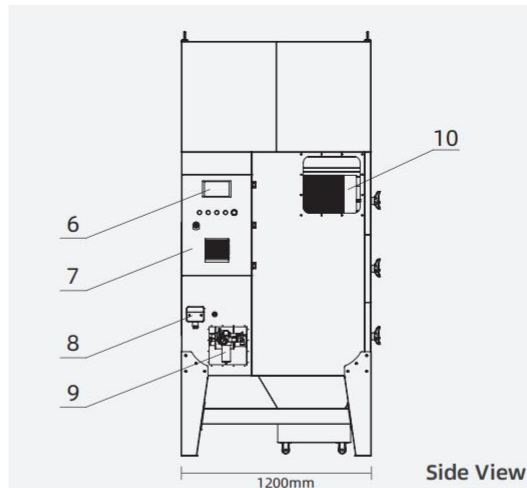
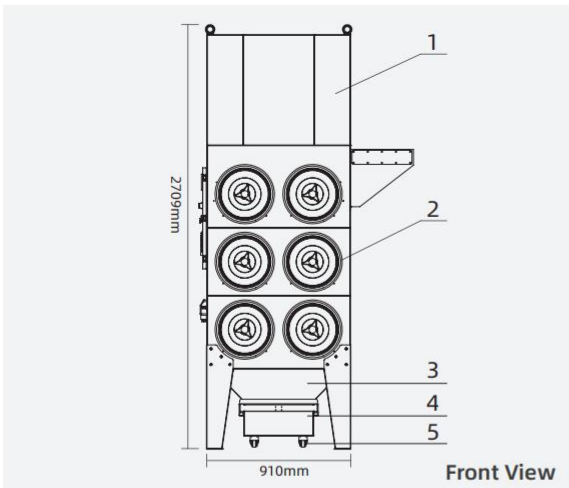

1. Fan cavity
2. High-precision nano filter cartridge
3. Hopper/ash collection hopper
4. Dust box
5. Universal wheel
6. PLC control screen
7. Electric box
8. Power supply line
9. Oil-water separator
10. Maintenance door
11. Air Inlet
12. Air outlet

Selection Parameter Table

Product number	SCT8-750D6	remote control	have
product type	Standard	Automatic dust cleaning	automatic
Dimensions	952*1257*2709mm	Filter cartridge material	Nano flame retardant/Polyester
Fan brand	Shengchuan	Filter cartridge specifications	324*660mm
Fan power	7.5KW	Number of filter cartridges	6
Full pressure	3300-3100	Filter area	111m ²
Air volume	6000-7000m ³ /h	Dust removal efficiency	99.5%
Control System	automatic	Equipment noise	70dB±5
Intelligent frequency conversion	Optional	weight	580KG

Product pictures and external dimensions are for reference only and shall prevail in kind.



Application Areas

Shengchuan SCT8 industrial cartridge dust collector can be widely used to purify smoke and dust generated in various industries, steel, electric power, building materials, new energy, lithium battery, photovoltaic, chemical industry, food, electronics and other industries. The product has high purification efficiency and low noise. It has the characteristics of low life, long service life and small floor space.

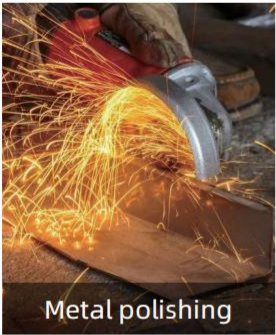

Metal polishing



Plasma cutting

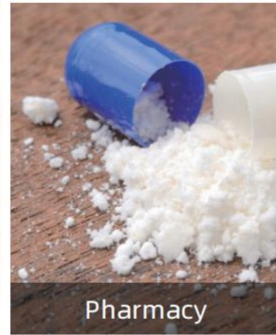

Pharmacy



Thermal spraying

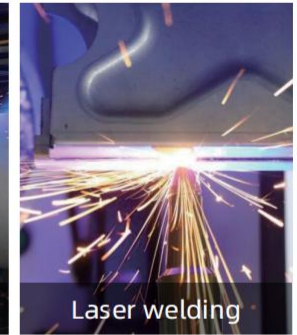

Laser welding

Live Cases

Shanghai Shengchuan Environmental Protection Technology Co., Ltd. is equipped with high-quality engineering and technical service engineers, specializing in after-sales service. Convenient and timely to provide users with quality and satisfactory service is the commitment of Shanghai Shengchuan Environmental Protection Company.



Optional Accessories



Spiral ventilation duct



Frequency converter



Temperature Sensor



Flameless relief device



Pipe spark arrester



Fire damper



Explosion proof valve



Automatic fire extinguisher



Spark detector



Explosive leaks